

# The “Extended XOR operator” as a consistent interpretation of George Spencer Brown’s “Distinction” (in [Laws of Form](#))

by [George A. Stathis](#)

18 August 2007

Richard Shoup has commented about Multiple Form Logic, and about the use of the XOR operator (as an *interpretation* of Distinction) as follows:

*-XOR is at minimum a binary operator. NOR (if you must cast Distinction into a traditional operator) can be unary (= NOT). XOR is not an appropriate interpretation of the Distinction in logic, and leads to various mathematical difficulties, as Bricken has commented before.*

Leaving -for a moment- aside the objection that “XOR is not a unary operator” (which is *not* a serious drawback, as I will try to show later), the remaining part of this comment seems to be the *exact opposite* of what is actually the case, i.e.

- *XOR is an appropriate interpretation of the Distinction in logic,*
- *XOR leads to freedom from various mathematical difficulties (see [2]).*

Furthermore,

**William Bricken’s Logic (i.e. his “Boundary Algebra”) is *–provably–* a special instance of Multiple Form Logic ([Theorem T12 in MF Logic](#)).**

So, *is XOR* an appropriate interpretation of Distinction? And if so, in what way is it a *better interpretation* than NOT?

1) We can regard the XOR operator as a *programmable gate*:

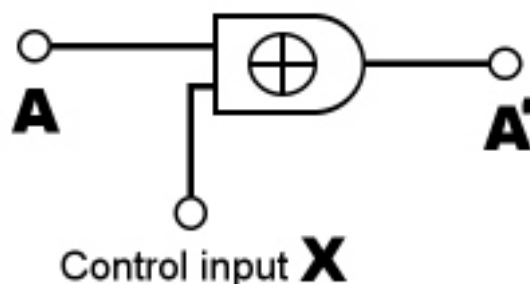

if  $X = 0$ ,  $A' = A$  (no distinction)

if  $X = 1$ ,  $A' = \text{not}(A)$  (distinction)

If, furthermore, A spreads out into multiple OR-ed parallel inputs, what we get is a programmable NOR/OR-gate. This programmable gate behaves as a NOR-gate when the

control input X is set to 1, while it behaves like an OR-gate when the control input X is set to zero. **It is not difficult to see, now, that *the control input X is effectively a programmable distinction (in Brownian terminology) over the space of the distinctions fed into A (as OR-ed parallel inputs):***

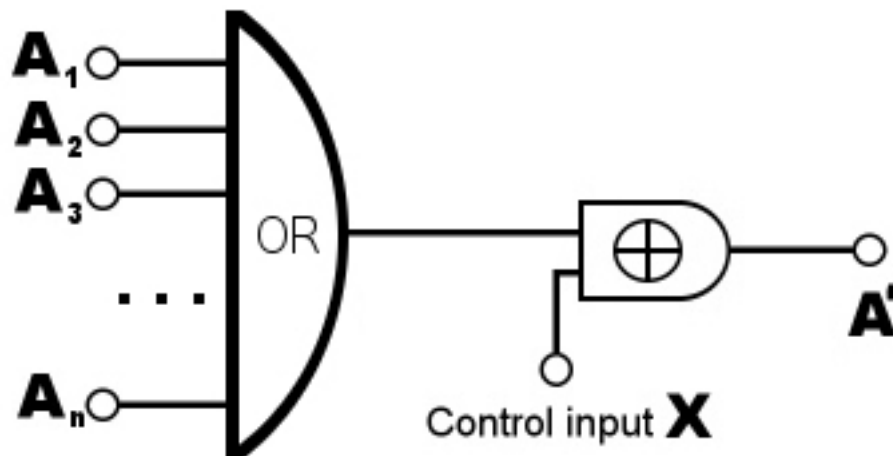

if X is  $\neg$  then A' is  $\overline{A_1 A_2 \dots A_n}$   
 if X is            then A' is  $A_1 A_2 \dots A_n$

Evidently, what we get here is a programmable Brownian space of OR-ed distinctions, in which X determines if the whole space is to be placed inside another distinction, or if it is to be kept unchanged.

**I.e. the input X determines if a distinction is to be *drawn* or *not drawn* (on the whole space). *The new possibilities for Self-modifying Programmable Logic Circuits are evident, as are the connections with classic temporal circuits, with XOR feedback.***

Now, *what* are the semantics of the XOR operator, in an expression like “A xor B”?  
**-“Either A, or B, but not both”.**

**Philosophically (or intuitively) a particular (local) observer can NOT be located both inside and outside a boundary. However, if one insists to be located both inside and outside a given boundary, then this boundary becomes effectively non-existent. (Since the very meaning of the term “boundary” entails restriction to be on one side).**

In fact, the XOR operator as a depiction of “containment” or of “distinction”, exhibits all the expected properties of such an interpretation, in all (four) cases:

- 1) If A and B are *both* empty spaces, there is no distinction between them (0).
- 2) If A expresses a distinction 1 and B is empty, the result is a distinction (1).
- 3) If A is empty and B expresses a distinction 1, the result is a distinction (1).
- 4) If both A and B are (the same) distinction 1, they cancel each other (0).

In addition, the XOR operator can also be regarded as unary, but if this is done then there are **two possibilities**: **The second input (of XOR) is either a marked or an unmarked state. If it is a marked state**, then the operator reduces to NOT (or NOR, if you prefer, with only one input). **If it is an unmarked state**, then the operator reduces to “self-sameness” or *no* distinction, leaving everything *as it was before*. *I.e. the second input’s state is no more and no less than the distinction itself.*

Now, there is only *one* “problem” with the XOR operator: **It is symmetric, i.e.**

$$A \text{ xor } B = B \text{ xor } A.$$

This commutative property, in Brownian terminology means that we can turn the *inside* into the *outside*, and vice versa, i.e.

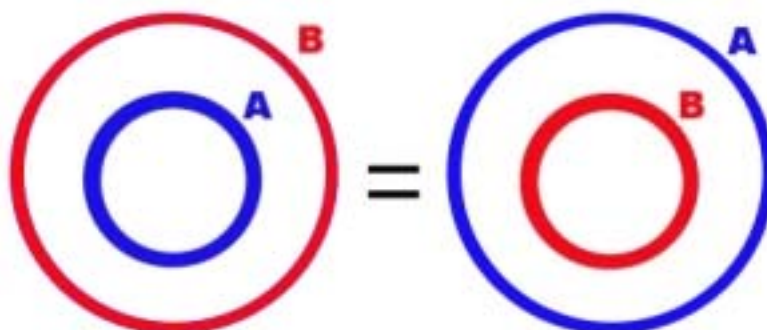

However, this is partly illusory. For example, if there exist distinctions A, B in the spaces inside and outside a distinction X, then **it is not possible to swap them**:

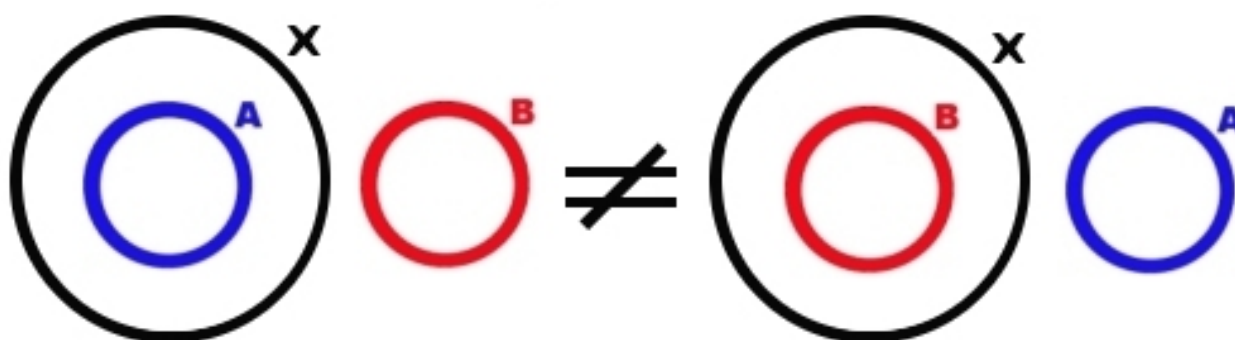

I.e. it is certainly possible to swap A and X in an expression “A xor X”, but it is *not* possible to swap A and B in an expression like “(A xor X) or B”. Nevertheless, if we insist, we may regard “containment” as an “extended XOR” (say ‘#’) where symmetry does *not* hold, i.e. “X # Y” is *not* “Y # X”. However, if we do this, then **expressions like “A # B # A” are not reducible** (by “cancellation”, [Axiom 2 of Multiple Form Logic](#)) to B. Numerous *interesting new possibilities arise*. E.g. We may define relations such as:

$$A \# B \# A = B \# A$$

**A # B # C # A = C # B**  
**(and so on...)**

There is nothing to stop this, apart from the fact we have to accept all the *formal consequences* (ideally using theorem-proving software to be able to check out the consequences quickly). Certainly *some* new relations will lead to contradictions or loss of information. *This area is new and unexplored.* However, when using the term “extended XOR” we also refer to the fact that in Multiple Form Logic there is not just one form (or two truth values) but a truly unlimited number of them. In this case, the meaning of “A xor B” is no longer confined to the binary situation 0 and 1 (or “Void” and “Form”). For example, we may wish to express a (pseudo-) philosophical statement like “The distinction between good and evil is Moral Wisdom”, through an “extended XOR” relation such as “GOOD # EVIL = MoralWisdom”. Clearly, in colloquial terms, *the distinction between Good and Evil is exactly the same as the distinction between Evil and Good.* In other words, *this kind of symmetry (in distinctions) is already implicit in human language!*

**So, on what grounds can it be claimed that XOR is an *inappropriate interpretation of distinction*? Clearly it is possible to model Brown’s arithmetic using OR and XOR. This is a superior way of doing such modeling from a mathematical point of view, as well as more appropriate *philosophically*, in certain ways. Well, in the end it is perhaps an issue of *taste* or subjective *doctrine*. In this case, it has no formal, logical or philosophical basis and it should not concern us any further!**

### **In Conclusion:**

- **“Laws of Form” is based on two *implicitly defined* relations between forms, which correspond to two “*arithmetic axioms*”. These two relations are then regarded (by George Spencer Brown and many of his disciples) as mathematically equivalent to the operators OR and NOR. If we adopt this interpretation, then using NOR (instead of XOR) has serious drawbacks, e.g. when modeling large *composite expressions containing XOR*. The number of (OR- and NOR-) terms required to model composite XOR-relations in this system rises steeply and prohibitively (as shown in [2] below). If we insist that XOR is “*inappropriate*”, just because George Spencer-Brown and William Bricken say so(!) then we achieve nothing but *unnecessary mathematical (and expressive) difficulties*. The myth that XOR “*causes mathematical difficulties*” is evidently the *exact opposite of the truth*.**

### **Further references:**

- 1) [http://multiforms.netfirms.com/multiforms\\_1.html#or\\_and\\_xor](http://multiforms.netfirms.com/multiforms_1.html#or_and_xor) (All we need is OR and XOR)
- 2) [http://multiforms.netfirms.com/mf\\_efficiency.html](http://multiforms.netfirms.com/mf_efficiency.html) (especially the complexity table in the end)
- 3) [http://omadeon.com/logic/mflogic\\_simplified.html](http://omadeon.com/logic/mflogic_simplified.html) (The advantages of MF logic)
- 4) <http://omadeon.wordpress.com/2007/05/31/equalitylogics> (on “Equality Logic”).
- 5) [http://multiforms.netfirms.com/more\\_theorems.html](http://multiforms.netfirms.com/more_theorems.html) (Theorem T12 in MF Logic)
- 6) <http://multiforms.netfirms.com> (home page of the Multiple Form Logic site)